



Bulletin No. 2017-02

First Release:

April 12, 2017

Prepared by:

Remington Brown,
Senior Engineering Director

Applicable Standards:

FORTIFIED Home™–Hurricane

Applicable Designation Level:

Retrofit for Ladder Framed Gable Overhang 12–18 in. Depth

Abstract

Older homes are often constructed with overhangs greater than 12 in. in depth. FORTIFIED standards limit overhangs on gable ends to 12 in. This bulletin provides prescriptive instructions, for the site condition limitations outlined below, on how to retrofit ladder framing on gable end overhangs to achieve a maximum depth of 18 in. from the face of the wall.

Site Condition Limitation**Exposure B****Mean Roof Height = 30 ft maximum**

Wind Provision	ASCE 7-10
Wind Speed (mph)	160 (ultimate)

Requirements

FORTIFIED Home™ requirements have not changed. This prescriptive retrofit utilizes 2x framing members and 7/16-in. structural sheathing (plywood or OSB) at soffits to form a structural box which will enable an existing gable overhang to extend 18 in. to the outermost surface of the overhang without site-specific engineering.

Documentation Requirements

All components installed must be documented with photos and verified by a certified FORTIFIED Evaluator. Required photos include all installed framing and sheathing. Include photos of fasteners which clearly indicate sizes and spacing of the fasteners installed as well as at least one overview showing the continuous ledgers in place.

Bulletin No. 2017-02

First Release:

April 12, 2017

Prepared by:

Remington Brown,
Senior Engineering Director

Applicable Standards:

FORTIFIED Home™—Hurricane

Applicable Designation Level:



For Evaluators Only: Evaluation Form Input

Overhang retrofit documentation photos, material invoices, etc., should be uploaded into the SOFFIT section of the evaluation in FOCUS.

Retrofit Specifications

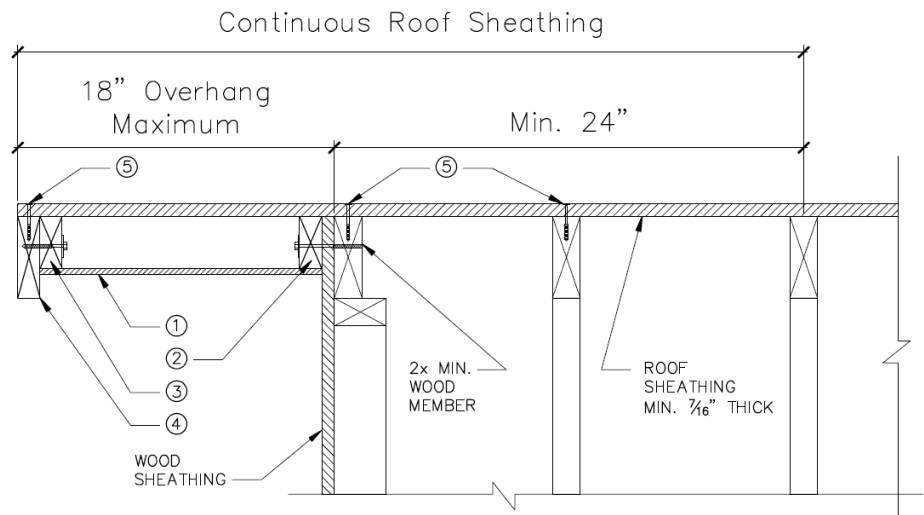

1. $\frac{7}{16}$ -in. structural sheathing (plywood or OSB) fastened to 2- x 4-in. ledgers with 8d nails at 3 in. o.c. at each end. Provide 2- x 4-in. blocking at all soffit panel joints.
2. 2- x 4-in. continuous ledger fastened to wall framing through exterior sheathing with #10 x 4-in.-long deck screw and a 1.5-in.-diameter washer at 6 in. o.c. and 3 in. from each end of the ledger.
3. 2- x 4-in. continuous ledger fastened to 2- x 6-in. fascia with #10 x 3-in.-long deck screw and a 1.5-in.-diameter washer at 8 in. o.c. and 3 in. from each end of the ledger.
4. 2x minimum fascia board.
5. Nail the roof deck to the fascia and first and second rafters with 8d ring shank nails at 4 in. o.c. (minimum $1\frac{3}{8}$ -in. penetration).